

# IFBB SET-UP SHEET

NAME: \_\_\_\_\_  
 DATE: \_\_\_\_\_  
 TRACK: \_\_\_\_\_  
 EVENT: \_\_\_\_\_

TRACK		
TRACK SIZE	<input type="checkbox"/> SMALL	<input type="checkbox"/> MEDIUM <input type="checkbox"/> LARGE
GRIP LEVEL	<input type="checkbox"/> LOW	<input type="checkbox"/> MEDIUM <input type="checkbox"/> HIGH
TRACK CONDITION	<input type="checkbox"/> SMOOTH	<input type="checkbox"/> GROOVED <input type="checkbox"/> BUMPY
	<input type="checkbox"/> WET	<input type="checkbox"/> DUSTY <input type="checkbox"/> LOAMY

COMMENTS

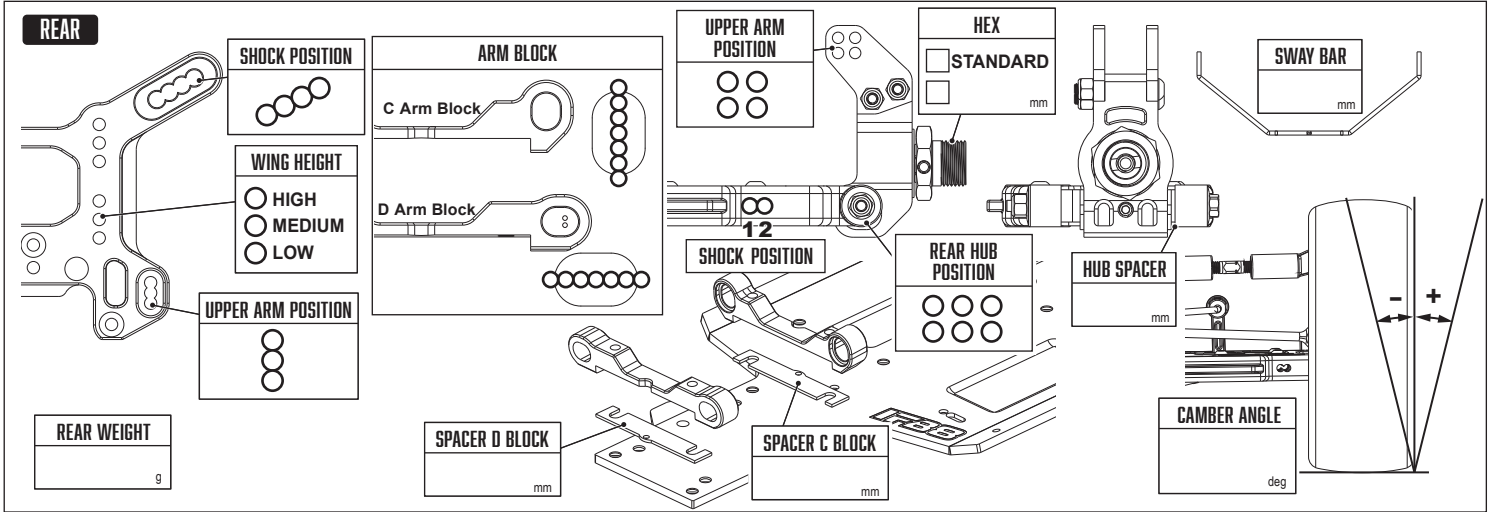
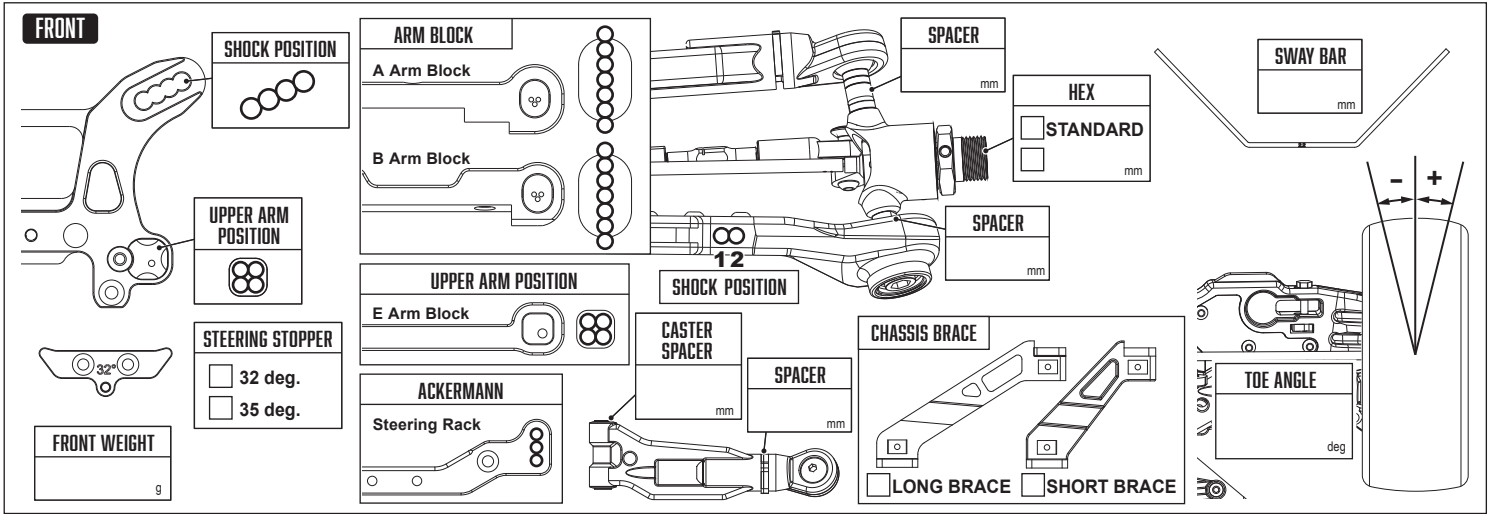

FRONT	SHOCKS	REAR
	OIL	
	SPRING	
	PISTON HOLES	
	MEMBRANE	
	EMULSION	
NOTES:		

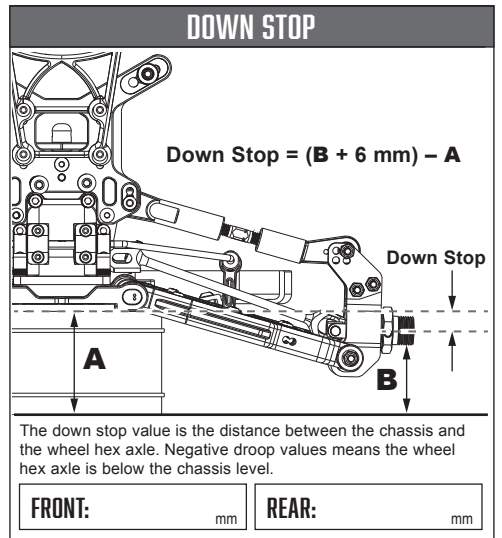
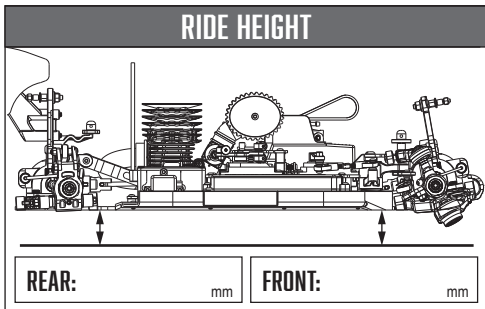

FRONT	DIFFS OIL GRADE	REAR
	CENTER	
NOTES:		

**CLUTCH & GEARING**

SPUR GEAR: \_\_\_\_\_ BELL: \_\_\_\_\_

SHOES: \_\_\_\_\_

SPRING: \_\_\_\_\_

NOTES: \_\_\_\_\_

**ENGINE**

TYPE: \_\_\_\_\_

PIPE: \_\_\_\_\_

MANIFOLD: \_\_\_\_\_

PLUG: \_\_\_\_\_

RESTRICTOR: \_\_\_\_\_

FUEL: \_\_\_\_\_

**BODY & WING**

BODY: \_\_\_\_\_

WING: \_\_\_\_\_

NOTES: \_\_\_\_\_

**TIRES**

TIRE: \_\_\_\_\_

INSERT: \_\_\_\_\_

WHEEL: \_\_\_\_\_

NOTES: \_\_\_\_\_